

SERIES
SERIE

KB

*For dry operation only
Solo per funzionamento a secco*

*Operating pressure 80 PSI
Pressione massima 6 bar*

*For horizontal axis mounting only
Solo per montaggio ad asse orizzontale*

*Available also as clutch or brake only
Utilizzabile anche nella versione
solo freno o solo frizione*

*Friction material asbestos free
Materiale d'attrito senza amianto*



SERIES
SERIE

HT

AIR ACTUATED CLUTCH - BRAKE UNIT (DRY)

GRUPPO FRENO - FRIZIONE A COMANDO PNEUMATICO (A SECCO)



HT GRUPPO FRENO - FRIZIONE A COMANDO PNEUMATICO HT

AIR ACTUATED CLUTCH - BRAKE UNIT

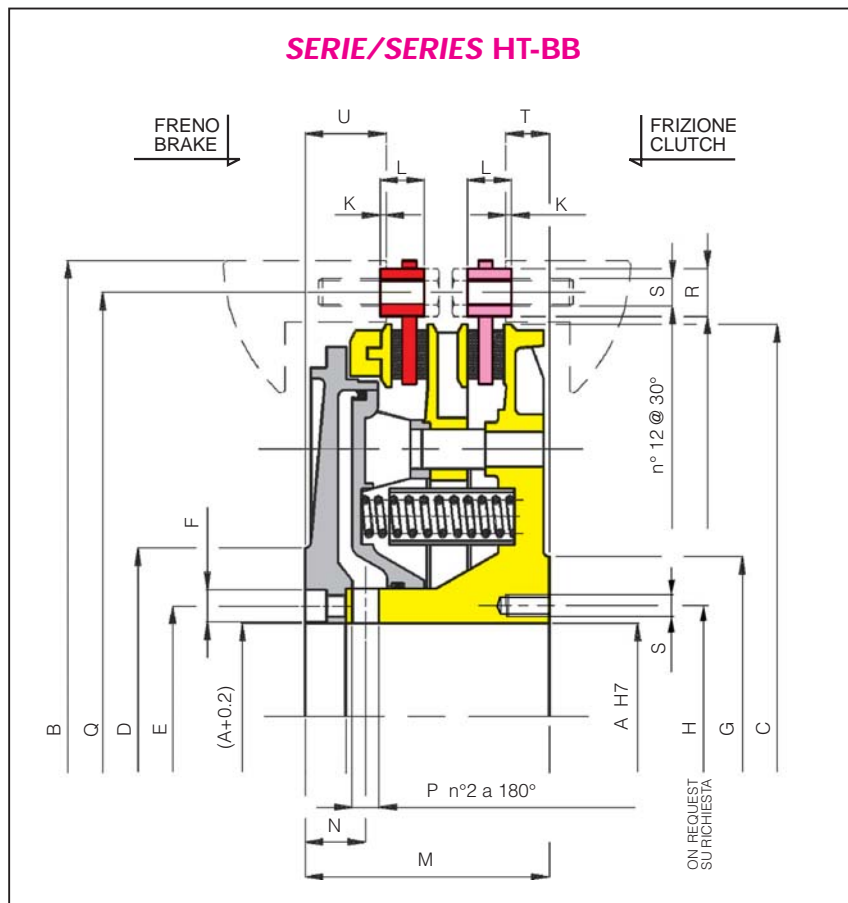

TIPO TYPE	HT 0125		HT 0260		HT 0350		HT 0490		HT 0770		HT 1000		HT 1500		HT 2150		HT 2900		HT 3900		HT 5800		HT 8000									
	inch	mm	inch	mm	inch	mm	inch	mm	inch	mm	inch	mm	inch	mm	inch	mm	inch	mm	inch	mm	inch	mm	inch	mm	inch	mm						
A max	2.559	65	3.543	90	3.740	95	4.134	105	4.921	125	5.709	145	6.299	160	7.087	180	7.874	200	8.661	220	9.449	240	10.630	270								
A min	1.693	43	1.969	50	1.969	50	2.165	55	2.559	65	3.543	90	3.937	100	4.921	125	5.118	130	5.118	130	5.512	140	5.906	150								
B	13.66	347	17.13	435	18.98	482	21.06	535	24.41	620	26.77	680	30.51	775	34.06	865	37.40	950	40.35	1.025	45.08	1.145	50.59	1.285								
C	11.97	304	14.96	380	16.54	420	18.31	465	21.38	543	23.35	593	26.57	675	29.72	755	32.68	830	35.63	905	39.96	1.015	44.88	1.140								
D	5.31	135	7.17	182	7.68	195	8.50	216	9.37	238	10.83	275	11.42	290	12.99	330	14.17	360	14.96	380	16.54	420	19.69	500								
E	3.23	82	4.33	110	4.53	115	5.04	128	5.98	152	6.85	174	7.48	190	8.27	210	9.25	235	10.24	260	11.22	285	12.60	320								
F	0.69	17,5	0.63	16	0.71	18	0.71	18	0.83	21	0.94	24	0.98	25	0.98	25	1.18	30	1.34	34	1.65	42	1.65	42								
G	4.92	125	6.50	165	7.28	185	8.27	210	8.86	225	10.43	265	11.61	295	12.20	310	14.17	360	15.16	385	17.72	450	19.69	500								
H	3.94	100	4.33	110	4.53	115	5.04	128	5.98	152	6.89	175	7.48	190	8.27	210	9.25	235	10.24	260	11.22	285	12.60	320								
K	0.12	3	0.12	3	0.12	3	0.12	3	0.12	3	0.16	4	0.16	4	0.20	5	0.20	5	0.20	5	0.31	8	0.31	8								
L	0.79	20	0.75	19	0.94	24	0.94	24	1.02	26	1.18	30	1.38	35	1.61	41	1.77	45	1.77	45	1.97	50	2.17	55								
M	4.09	104	4.63	117,5	5.16	131	5.89	149,5	6.65	169	7.56	192	8.66	220	9.55	242,5	10.39	264	10.81	274,5	12.22	310,5	13.90	353								
N	1.10	28	1.28	32,5	1.42	36	1.67	42,5	1.87	47,5	2.01	51	2.44	62	2.66	67,5	2.99	76	3.25	82,5	3.60	91,5	4.25	108								
P	0.43	11	0.51	13	0.55	14	0.63	16	0.71	18	0.79	20	0.83	21	0.91	23	0.98	25	1.18	30	1.26	32	1.38	35								
Q	12.80	325	16.06	408	17.72	450	19.69	500	22.99	584	25.20	640	28.54	725	31.89	810	35.04	890	37.99	965	42.52	1.080	47.83	1.215								
R	0.591	15	0.709	18	0.866	22	0.984	25	0.984	25	1.181	30	1.378	35	1.614	41	1.772	45	1.772	45	1.969	50	2.165	55								
S		M8		M10		M12		M14		M14		M16		M20		M24		M24		M24		M27		M30								
T	0.43	11	0.57	14,5	0.61	15,5	0.71	18	0.85	21,5	1.06	26,8	1.17	29,8	1.31	33,3	1.42	36	1.34	34	1.65	42	1.97	50								
U	1.61	41	1.89	48	2.05	52	2.60	66	2.80	71	3.04	77,3	3.61	91,8	3.89	98,8	4.21	107	4.39	111,5	4.78	121,5	5.51	140								
V	8.19	208	10.87	276	11.89	302	13.86	352	16.34	415	17.64	448	20.28	515	22.52	572	24.33	618	26.77	680	30.12	765	33.86	860								
YY	9.84	250	12.68	322	13.98	355	15.42	395	17.11	435	18.96	480	21.04	535	23.37	595	25.96	660	28.80	730	31.92	810	35.34	895	39.37	1.000						
	U.S.	Metric	U.S.	Metric	U.S.	Metric	U.S.	Metric	U.S.	Metric	U.S.	Metric	U.S.	Metric	U.S.	Metric	U.S.	Metric	U.S.	Metric	U.S.	Metric	U.S.	Metric	U.S.	Metric	U.S.	Metric				
Massima velocità/RPM Max speed/RPM	1.800	1.800	1.500	1.500	1.400	1.400	1.250	1.250	1.100	1.100	1.000	1.000	850	850	750	750	700	700	630	630	560	560	500	500								
Peso Kg - Weight LBS	50.7	23	103.6	47	143.3	65	187.4	85	291.1	132	405.7	184	573.3	260	754.1	342	1,069.4	485	1,289.9	585	1,808.1	820	2,535.8	1,150								
Valore Cilindro (nuovo) lt Cylinder capacity (new) IN³	14.04	0,23	27.46	0,45	33.56	0,55	51.26	0,84	75.67	1,24	94.59	1,55	133.03	2,18	176.97	2,90	241.04	3,95	295.97	4,85	396.66	6,50	494.29	8,10								
Valore Cilindro (usurato) lt Cylinder capacity (worn) IN³	17.09	0,28	39.06	0,64	44.55	0,73	72.01	1,18	103.74	1,70	134.25	2,20	189.17	3,10	247.15	4,05	352.72	5,78	408.86	6,70	585.83	9,60	762.80	12,50								
Inerzia J Corpo Kg·m² Inertia WR² Body LB·FT	4.27	0,18	12.34	0,52	19.69	0,83	33.45	1,41	69.75	2,94	118.63	5,00	208.79	8,80	367.75	15,50	588.40	24,80	890.91	37,55	1593.20	67,15	2813.90	118,60								
Inerzia J Anelli Kg·m² Inertia WR² Plates LB·FT	2.14	0,09	4.75	0,20	7.83	0,33	11.86	0,50	25.62	1,08	40.33	1,70	80.67	3,40	137.61	5,80	225.40	9,50	307.25	12,95	486.38	20,50	894.47	37,70								
Momento freno Nm Brake torque LB-IN	8.054	910	18.585	2.100	24.780	2.800	34.515	3.900	53.985	6.100	71.685	8.100	105.315	11.900	153.990	17.400	199.125	22.500	256.650	29.000	371.700	42.000	522.150	59.000								
Momento frizione (5,5 bar) Nm Clutch torque (@ 80 Psi) LB-IN	10.797	1.220	23.010	2.600	30.975	3.500	43.365	4.900	68.145	7.700	88.500	10.000	132.750	15.000	190.275	21.500	256.650	29.000	345.150	39.000	513.300	58.000	708.000	80.000								

Pressione di esercizio 5,5 Bar - Operating pressure 80 Psi - Pressione massima ammissibile 6 Bar - Max. Allowable pressure 87 Psi



HT

SERIE - SERIES HT

HT

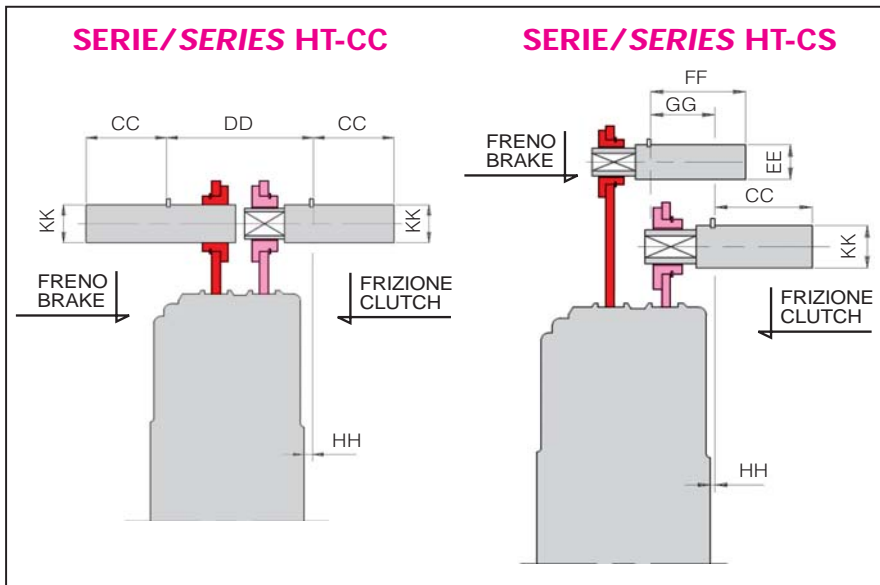
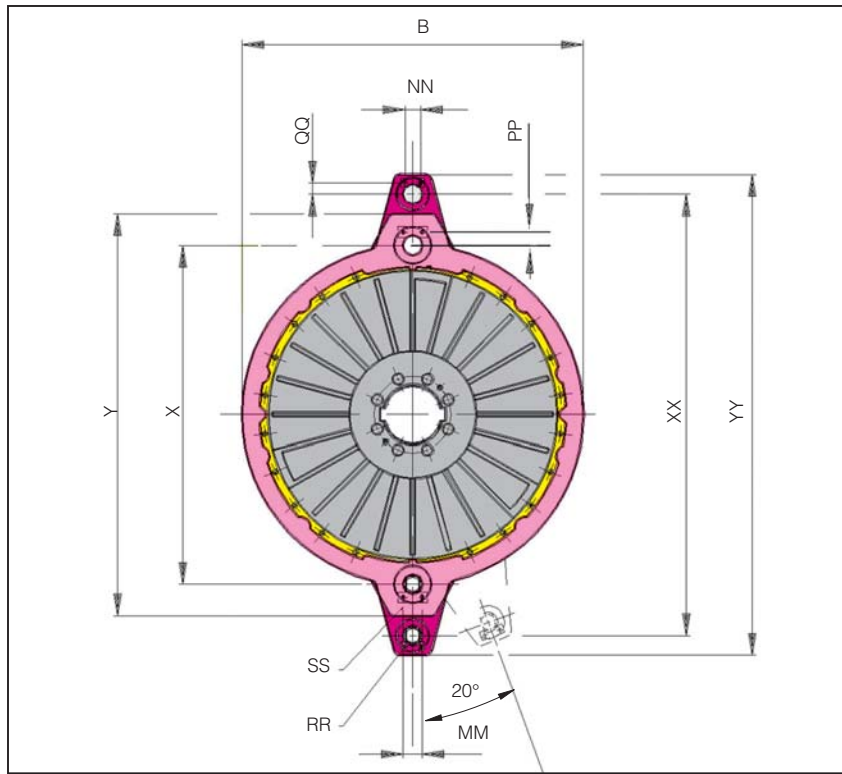
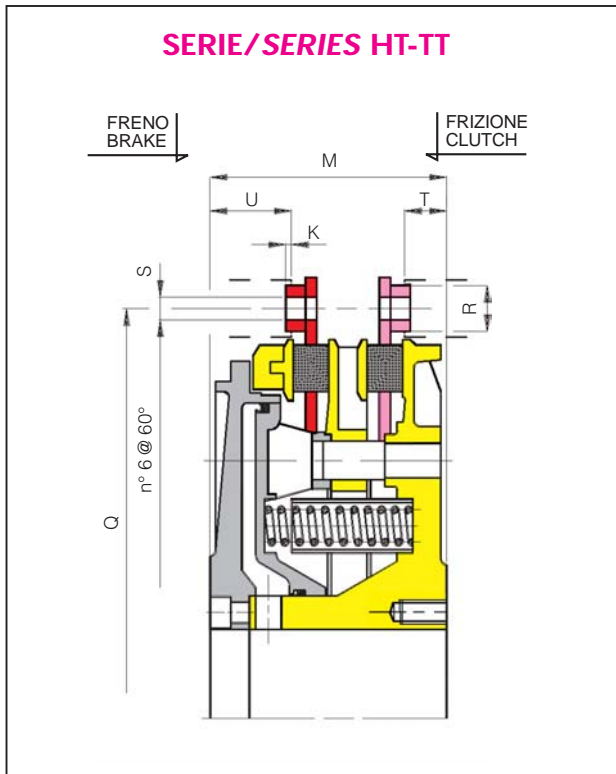

TIPO TYPE	HT 0125		HT 0260		HT 0350		HT 0490		HT 0770		HT 1000		HT 1500		HT 2150		HT 2900		HT 3900		HT 5800		HT 8000	
	inch	mm	inch	mm	inch	mm	inch	mm	inch	mm	inch	mm	inch	mm	inch	mm	inch	mm	inch	mm	inch	mm	inch	mm
CC	1.77	45	2.36	60	2.56	65	3.15	80	3.15	80	3.54	90	4.33	110	4.33	110	5.91	150	5.91	150	5.91	150	7.09	180
DD	3.58	91	4.13	105	4.21	107	5.04	128	5.83	148	6.22	158	7.28	185	7.64	194	9.45	240	9.61	244	10.00	254	11.42	290
EE	0.630	16	0.866	22	1.181	30	1.181	30	1.181	30	1.575	40	1.772	45	1.772	45	2.559	65	2.559	65	2.559	65	2.953	75
FF	1.10	28	1.77	45	2.36	60	2.36	60	2.36	60	3.15	80	3.54	90	3.54	90	5.12	130	5.12	130	5.12	130	5.91	150
GG	1.93	49	2.36	60	2.13	54	2.62	66,5	3.17	80,5	3.19	81	3.88	98,5	4.23	107,5	4.74	120,5	4.90	124,5	5.30	134,5	6.22	158
HH	0.39	10	0.47	12	0.28	7	0.41	10,5	0.51	13	0.49	12,5	0.71	18	0.49	12,5	1.04	26,5	0.89	22,5	0.65	16,5	0.77	19,5
KK	0.866	22	1.181	30	1.260	32	1.575	40	1.575	40	1.772	45	2.165	55	2.165	55	2.953	75	2.953	75	2.953	75	3.543	90
MM	0.98	25	0.98	25	0.98	25	1.38	35	1.38	35	1.38	35	1.77	45	1.77	45	2.36	60	2.36	60	2.36	60	2.36	60
NN	0.79	20	0.98	25	0.98	25	0.98	25	0.98	25	1.38	35	1.38	35	1.38	35	1.77	45	1.77	45	1.77	45	2.36	60
PP	0.63	16	0.79	20	0.83	21	1.06	27	1.06	27	1.16	29,5	1.52	38,5	1.52	38,5	2.07	52,5	2.07	52,5	2.07	52,5	2.36	60
QQ	0.43	11	0.63	16	0.79	20	0.79	20	0.79	20	1.06	27	1.16	29,5	1.16	29,5	1.71	43,5	1.71	43,5	1.71	43,5	2.07	52,5
RR	0.177	4,5	0.217	5,5	0.217	5,5	0.217	5,5	0.217	5,5	0.256	6,5	0.256	6,5	0.256	6,5	0.335	8,5	0.335	8,5	0.335	8,5	0.413	10,5
SS	0.217	5,5	0.217	5,5	0.217	5,5	0.256	6,5	0.260	6,6	0.256	6,5	0.335	8,5	0.335	8,5	0.413	10,5	0.413	10,5	0.413	10,5	0.413	10,5
X	15.35	390	19.49	495	21.65	550	24.02	610	27.36	695	30.31	770	34.65	880	38.19	970	43.31	1.100	46.46	1.180	51.18	1.300	57.68	1.465
YY	17.83	453	22.64	575	24.41	620	27.87	708	31.22	793	34.72	882	39.69	1.008	43.70	1.110	49.76	1.264	52.91	1.344	57.48	1.460	64.96	1.650
XX	19.29	490	25.00	635	27.95	710	31.10	790	34.84	885	38.98	990	44.69	1.135	48.62	1.235	57.09	1.450	60.04	1.525	64.76	1.645	73.03	1.855
YY	20.55	522	27.32	694	30.51	775	34.25	870	37.99	965	42.83	1.088	49.09	1.247	53.50	1.359	63.39	1.610	65.71	1.669	70.75	1.797	79.25	2.013



FLANGIA ADDUZIONE ARIA (solo per montaggio a sbalzo - opzionale) SUFFISSO F AIR INLET FLANGE - optional (for end assembly only) SUFFIX F

SUFFISSO F (esecuzione standard) - SUFFIX F (standard version)

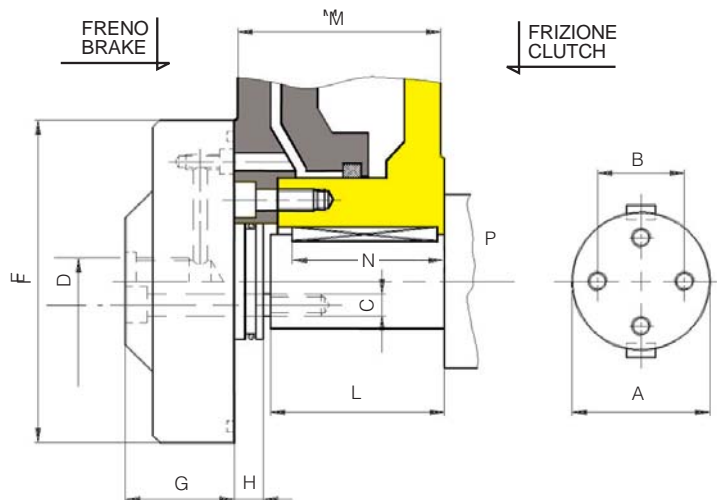

TIPO TYPE	HT 0125		HT 0260		HT 0350		HT 0490		HT 0770		HT 1000		HT 1500		HT 2150		HT 2900		HT 3900		HT 5800		HT 8000	
	inch	mm	inch	mm	inch	mm	inch	mm	inch	mm	inch	mm	inch	mm	inch	mm	inch	mm	inch	mm	inch	mm	inch	mm
A max	2.559	65	3.543	90	3.740	95	4.134	105	4.724	120	5.512	140	6.299	160	7.087	180	7.874	200	8.661	220	9.449	240	10.630	270
A min	1.969	50	2.677	68	2.835	72	3.150	80	3.346	85	3.780	96	4.252	108	5.118	130	5.433	138	5.827	148	5.512	165	7.480	190
B	1.50	38	1.97	50	1.97	50	2.40	61	2.40	61	2.56	65	3.15	80	3.74	95	3.94	100	4.33	110	4.72	120	5.51	140
C		M8		M12		M12		M12		M14		M16		M16		M20		M20		M20		M24		M24
D	3/8"G 3/8"G		3/4"G 3/4"G		3/4"G 3/4"G		1"G 1"G		1"G 1"G		1"G 1"G		11/4"G 11/4"G		11/2"G 11/2"G		11/2"G 11/2"G		2"G 2"G		2"G 2"G		2"G 2"G	
F	5.04	128	7.17	182	7.68	195	8.66	220	9.37	238	10.71	272	11.61	295	12.28	312	14.17	360	14.96	380	16.54	420	19.69	500
G	1.378	35	1.693	43	1.693	43	2.047	52	2.047	52	2.126	54	2.441	62	3.031	77	3.031	77	3.543	90	3.740	95	3.937	100
H	0.33	8,5	0.33	8,5	0.33	8,5	0.33	8,5	0.33	8,5	0.33	8,5	0.33	8,5	0.33	8,5	0.51	13	0.39	10	0.59	15	0.59	15
L	3.54	90	3.98	101	4.49	114	5.08	129	5.87	149	6.85	174	7.64	194	8.62	219	9.06	230	9.84	250	11.02	280	12.40	315
M	4.09	104	4.63	117,5	5.16	131	5.89	149,5	6.65	169	7.56	192	8.66	220	9.55	242,5	10.39	264	10.81	274,5	12.22	310,5	13.90	353
N	3.23	82	3.66	93	4.37	111	4.92	125	5.04	128	6.57	167	7.28	185	8.23	209	8.86	225	8.86	225	10.04	255	11.22	285

GIUNTI ROTANTI PER ARIA E VUOTO (Alta velocità) SERIE R-U ROTATING JOINTS FOR AIR AND VACUUM (High speed) SERIES R-U

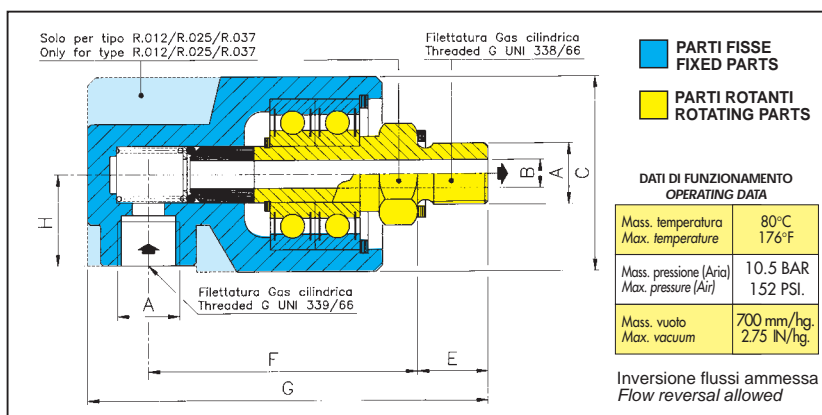

TIPO TYPE	A		B		C		D		E		F		G		H		PESO / WEIGHT		VELOCITÀ SPEED rpm
	NPT	BSP	Inch	mm	Inch	mm	Inch	mm	Inch	mm	Inch	mm	Inch	mm	Inch	mm	lbs	kg	
R 012	1/8"	1/8"G	0.177	4,5	1.38	35	0.55	14	0.43	11	1.65	42	2.48	63	0.59	15	0.51	0,23	3.000
R 025	1/4"	1/4"G	0.276	7	1.57	40	0.67	17	0.45	11,45	1.97	50	2.99	76	0.69	17,5	0.66	0,30	2.500
R 037	3/8"	3/8"G	0.394	10	1.89	48	0.87	22	0.63	16	2.36	60	3.54	90	0.81	20,5	0.95	0,43	2.000
R 050	1/2"	1/2"G	0.492	12,5	1.97	50	1.06	27	0.71	18	3.15	80	4.37	111	1.18	30	1.65	0,75	1.500
R 075	3/4"	3/4"G	0.669	17	2.20	56	1.26	32	0.79	20	3.39	86	4.80	122	1.42	36	2.12	0,96	1000
R 100	1"	1"G	0.866	22	2.56	65	1.61	41	0.93	23,5	3.86	98	5.43	138	1.57	40	3.09	1,40	700
U 125	11/4"	11/4"G	1.260	32	3.43	87	1.97	50	1.10	28	4.45	113	7.36	187	1.97	50	7.06	3,20	1.500
U 150	11/2"	11/2"G	1.496	38	3.70	94	2.17	55	1.22	31	4.61	117	7.76	197	2.17	55	8.60	3,90	1.000
U 200	2"	2"G	1.890	48	4.25	108	2.56	65	1.38	35	5.16	131	8.82	224	2.76	70	11.69	5,30	800



HT **VERSIONE CON CALETTATORE PER ATTRITO INTERNO** **HT**
INTERNAL CLAMPING DEVICE TYPE

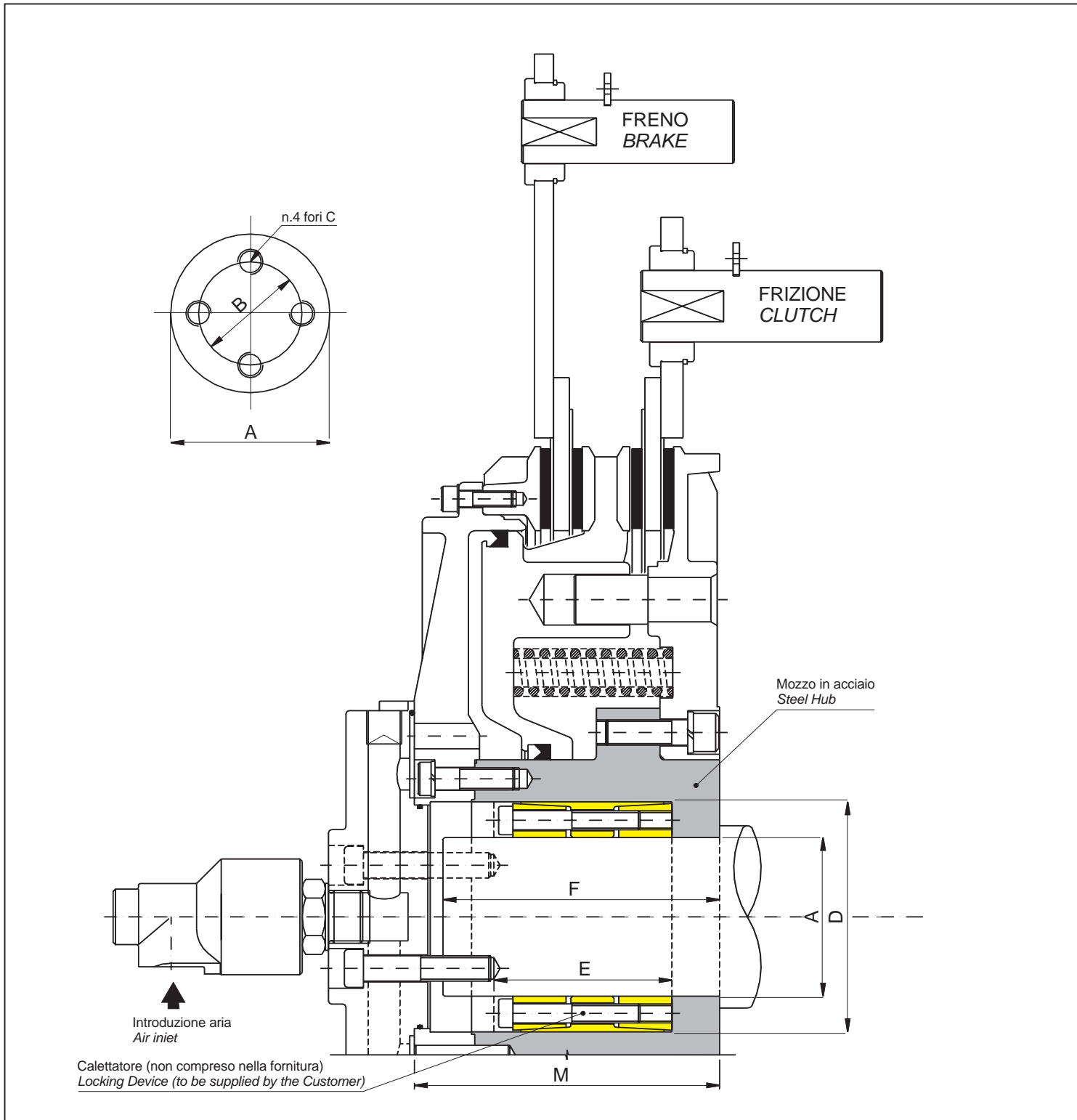

TIPO TYPE	HT 0260 inch mm	HT 0350 inch mm	HT 0490 inch mm	HT 0770 inch mm	HT 1000 inch mm	HT 1500 inch mm	HT 2150 inch mm	HT 2900 inch mm	HT 3900 inch mm	HT 5800 inch mm	HT 8000 inch mm
A	2.362 60	2.559 65	2.756 70	3.150 80	3.937 100	4.331 110	5.118 130	5.512 140	6.299 160	7.087 180	7.874 200
B	1.97 50	1.97 50	2.40 61	2.40 61	2.56 65	3.15 80	3.74 95	3.94 100	4.33 110	4.72 120	5.51 140
C	M12	M12	M12	M14	M16	M16	M20	M20	M20	M24	M24
D	3.543 90	3.346 85	3.937 100	4.724 120	5.709 145	6.102 155	7.087 180	7.480 190	8.268 210	9.252 235	10.236 260
E	2.83 72	2.83 72	2.83 72	3.46 88	4.41 112	4.41 112	5.12 130	5.12 130	5.12 130	6.38 162	6.38 162
F	3.35 85	3.66 93	4.21 107	5.87 149	6.85 174	7.64 194	8.62 219	9.06 230	9.53 242	10.91 277	12.28 312
M	4.63 117.5	5.16 131	5.89 149,5	6.65 169	7.56 192	8.66 220	9.55 242,5	10.39 264	10.81 274,5	12.22 310,5	13.90 353



HT **VERSIONE CON CALETTATORE PER ATRRITO ESTERNO** **HT**
EXTERNALSHRINK-DISK CONNECTED TYPE

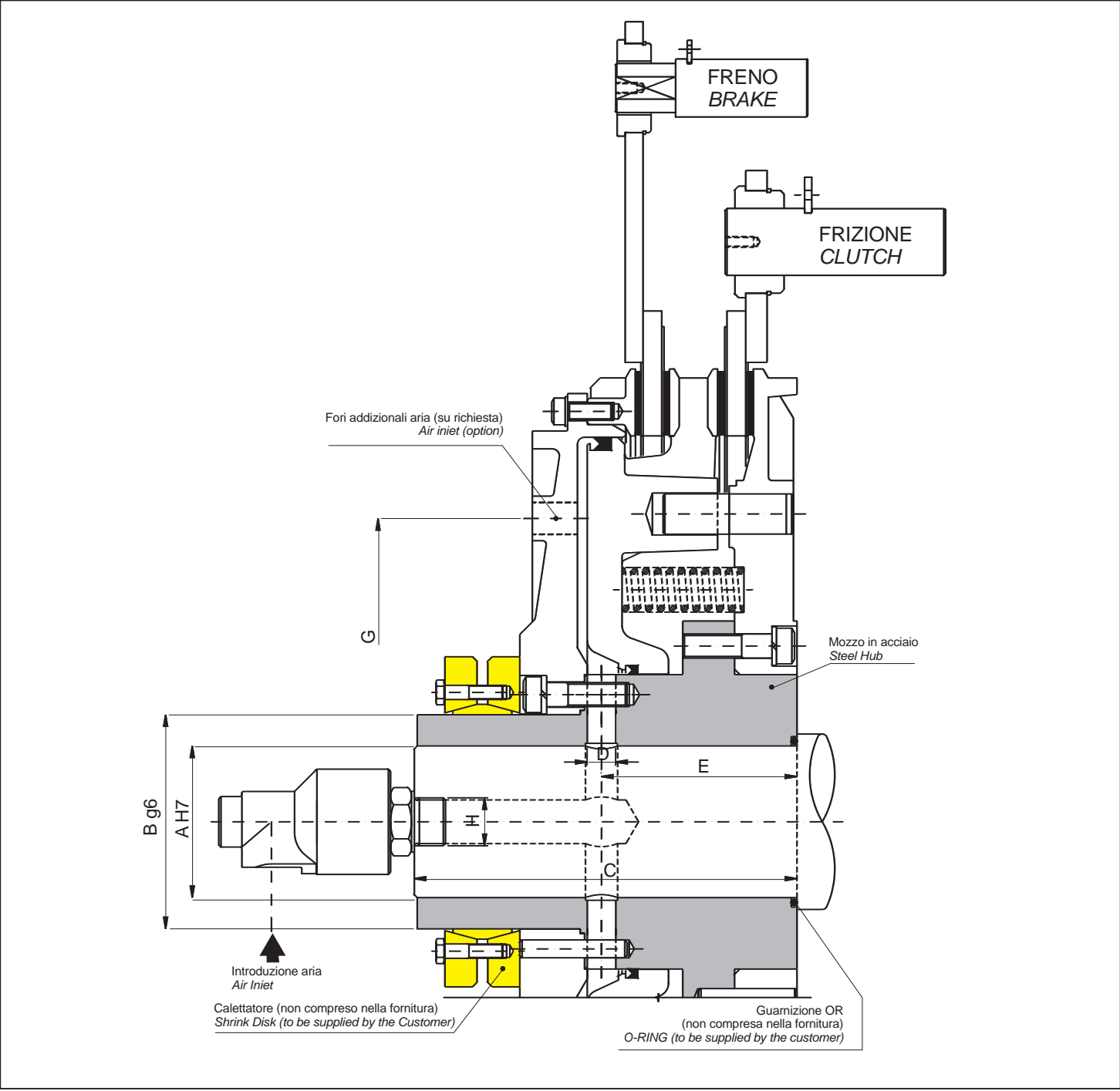

NOTE:

- 1 Per l'albero è prescritta una tolleranza h6 e per la zona di contatto col calettatore una Rt < 16 µm (Ra < 12 µm ca.).
- 2 Per le versioni con 6 e 9 molle, contattare la Casa produttrice.

NOTES:

- 1 The requested shaft diameter tolerance is h6 and for the contact surface between hub and shrink disk the prescription is Rt < 16 µm (Ra < 12 µm approx.).
- 2 If You need a 6 or 9 springs version, please contact the manufacturer.

TIPO TYPE	HT 0125 inch mm	HT 0260 inch mm	HT 0350 inch mm	HT 0490 inch mm	HT 0770 inch mm	HT 1000 inch mm	HT 1500 inch mm	HT 2150 inch mm	HT 2900 inch mm	HT 3900 inch mm	HT 5800 inch mm	HT 8000 inch mm
A max	2.047 52	2.953 75	2.953 75	3.150 80	3.740 95	4.134 105	4.528 115	5.315 135	6.299 160	6.693 170	7.480 190	8.268 210
A min	1.969 50	2.559 65	2.756 70	2.756 70	3.346 85	3.740 95	4.134 105	4.921 125	5.906 150	6.299 160	6.693 170	7.480 190
B	2.44 62	3.54 90	3.54 90	3.94 100	4.92 125	5.51 140	6.10 155	6.89 175	7.87 200	8.66 220	9.45 240	10.24 260
C	5.67 144	6.59 167,5	7.13 181	7.85 199,5	9.02 229	10.12 257	11.42 290	12.93 328,5	13.98 355	15.12 384	16.75 425,5	18.82 478
D	0.433 11	0.512 13	0.551 14	0.630 16	0.709 18	0.787 20	0.827 21	0.906 23	0.984 25	1.181 30	1.260 32	1.378 35
E	2.99 76	3.35 85	3.74 95	4.21 107	4.78 121,5	5.55 141	6.22 158	6.89 175	7.40 188	7.56 192	8.62 219	9.65 245
F	3/8"G 3/8"G	3/4"G 3/4"G	3/4"G 3/4"G	1"G 1"G	1"G 1"G	1"G 1"G	11/4"G 11/4"G	11/2"G 11/2"G	11/2"G 11/2"G	2"G 2"G	2"G 2"G	2"G 2"G
G	- -	10.12 257	10.83 275	12.36 314	13.82 351	15.87 403	15.98 406	19.02 483	21.65 550	24.37 619	26.77 680	27.95 710



GRUPPO FRENO - FRIZIONE A COMANDO PNEUMATICO AIR ACTUATED CLUTCH - BRAKE UNIT

Coppie del gruppo frizione/freno in rapporto al numero di molle
Clutch/brake unit torques versus unit's spring number

SERIE - SERIES HT

Grandezza Size	Ms Frizione Clutch Ms				Md Freno Brake Md		N°. Molle Spring Nr.
	@ 80 psi Lb-in	con 5,5 bar Nm	@ 87 psi Lb-in	con 6 bar Nm	Lb-in	Nm	
HT 0125 -...1	11,506	1.300	13,276	1.500	8,851	1.000	18
HT 0125 -...3	12,391	1.400	14,161	1.600	7,081	800	15
HT 0125 -...6	14,161	1.600	15,931	1.800	5,310	600	12
HT 0125 -...9	15,931	1.800	18,586	2.100	4,425	500	9
HT 0260 -...1	22,127	2.500	25,667	2.900	17,701	2.000	18
HT 0260 -...3	24,782	2.800	29,207	3.300	15,046	1.700	15
HT 0260 -...6	28,322	3.200	32,748	3.700	11,506	1.300	12
HT 0260 -...9	31,863	3.600	37,173	4.200	8,851	1.000	9
HT 0350 -...1	30,977	3.500	36,288	4.100	22,127	2.500	18
HT 0350 -...3	34,518	3.900	39,828	4.500	18,586	2.100	15
HT 0350 -...6	38,943	4.400	44,254	5.000	15,046	1.700	12
HT 0350 -...9	43,368	4.900	48,679	5.500	11,506	1.300	9
HT 0490 -...1	45,139	5.100	52,219	5.900	34,518	3.900	18
HT 0490 -...3	51,334	5.800	59,300	6.700	29,207	3.300	15
HT 0490 -...6	57,530	6.500	67,265	7.600	23,012	2.600	12
HT 0490 -...9	63,725	7.200	74,346	8.400	17,701	2.000	9
HT 0770 -...1	69,035	7.800	80,541	9.100	53,104	6.000	15
HT 0770 -...3	80,541	9.100	93,817	10.600	42,483	4.800	12
HT 0770 -...6	92,047	10.400	107,093	12.100	31,863	3.600	9
HT 0770 -...9	103,553	11.700	120,370	13.600	21,242	2.400	6
HT 1000 -...1	90,277	10.200	105,323	11.900	68,150	7.700	15
HT 1000 -...3	105,323	11.900	123,025	13.900	54,874	6.200	12
HT 1000 -...6	120,370	13.600	139,841	15.800	40,713	4.600	9
HT 1000 -...9	134,531	15.200	156,657	17.700	27,437	3.100	6
HT 1500 -...1	130,990	14.800	152,232	17.200	101,783	11.500	18
HT 1500 -...3	149,577	16.900	174,359	19.700	84,967	9.600	15
HT 1500 -...6	168,163	19.000	195,600	22.100	68,150	7.700	12
HT 1500 -...9	186,750	21.100	217,727	24.600	50,449	5.700	9
HT 2150 -...1	200,911	22.700	233,304	26.360	139,841	15.800	18
HT 2150 -...3	226,578	25.600	262,866	29.700	115,944	13.100	15
HT 2150 -...6	251,360	28.400	292,073	33.000	92,932	10.500	12
HT 2150 -...9	276,142	31.200	320,395	36.200	69,921	7.900	9
HT 2900 -...1	269,061	30.400	312,430	35.300	193,830	21.900	15
HT 2900 -...3	310,660	35.100	360,666	40.750	154,887	17.500	12
HT 2900 -...6	352,258	39.800	408,902	46.200	115,944	13.100	9
HT 2900 -...9	393,856	44.500	456,696	51.600	77,001	8.700	6
HT 3900 -...1	351,373	39.700	408,017	46.100	254,900	28.800	18
HT 3900 -...3	397,396	44.900	461,121	52.100	212,417	24.000	15
HT 3900 -...6	442,535	50.000	513,341	58.000	169,933	19.200	12
HT 3900 -...9	488,559	55.200	567,330	64.100	127,450	14.400	9
HT 5800 -...1	505,375	57.100	589,457	66.600	382,350	43.200	24
HT 5800 -...3	608,928	68.800	709,826	80.200	286,763	32.400	18
HT 5800 -...6	661,147	74.700	770,011	87.000	238,969	27.000	15
HT 5800 -...9	712,481	80.500	831,081	93.900	191,175	21.600	12
HT 8000 -...1	674,423	76.200	810,724	91.600	540,778	61.100	30
HT 8000 -...3	791,253	89.400	927,553	104.800	432,799	48.900	24
HT 8000 -...6	908,082	102.600	1,064,739	120.300	324,821	36.700	18
HT 8000 -...9	1,024,911	115.800	1,132,890	128.000	215,957	24.400	12

SERIE - SERIES KB

Grandezza Size	Ms Frizione Clutch Ms				Md Freno Brake Md		N°. Molle Spring Nr.
	@ 80 psi Lb-in	con 5,5 bar Nm	@ 87 psi Lb-in	con 6 bar Nm	Lb-in	Nm	
KB 0012 -...1	1,151	130	1,328	150	708	80	12
KB 0012 -...3	1,328	150	1,505	170	531	60	9
KB 0012 -...6	1,505	170	1,682	190	354	40	6
KB 0025 -...1	1,859	210	2,213	250	1,682	190	18
KB 0025 -...3	2,124	240	2,390	270	1,416	160	15
KB 0025 -...6	2,390	270	2,655	300	1,151	130	12
KB 0025 -...2	2,832	320	3,186	360	620	70	6
KB 0050 -...1	4,071	460	4,779	540	3,894	440	24
KB 0050 -...6	5,045	570	5,753	650	2,921	330	18
KB 0050 -...2	5,841	660	6,727	760	1,947	220	12
KB 0050 -...3	6,373	720	7,258	820	1,416	160	9
KB 0100 -...1	8,143	920	9,470	1.070	6,815	770	18
KB 0100 -...3	9,293	1.050	10,621	1.200	5,753	650	15
KB 0100 -...9	11,506	1.300	12,922	1.460	3,452	390	9
KB 0100 -...2	12,568	1.420	13,984	1.580	2,301	260	6
KB 0200 -...1	18,586	2.100	21,242	2.400	12,391	1.400	18
KB 0200 -...3	20,622	2.330	23,277	2.630	10,355	1.170	15
KB 0200 -...6	22,746	2.570	25,402	2.870	8,231	930	12
KB 0200 -...9	24,782	2.800	27,437	3.100	6,195	700	9
KB 0400 -...1	34,960	3.950	40,713	4.600	29,650	3.350	18
KB 0400 -...3	39,828	4.500	45,581	5.150	24,782	2.800	15
KB 0400 -...9	50,006	5.650	55,317	6.250	15,046	1.700	9
KB 0400 -...2	54,432	6.150	60,185	6.800	10,178	1.150	6
KB 0500 -...1	47,794	5.400	54,874	6.200	30,092	3.400	18
KB 0500 -...3	52,839	5.970	59,919	6.770	25,047	2.830	15
KB 0500 -...6	57,972	6.550	65,053	7.350	19,914	2.250	12
KB 0500 -...9	62,840	7.100	69,921	7.900	15,046	1.700	9
KB 0600 -...1	59,300	6.700	68,150	7.700	38,943	4.400	18
KB 0600 -...3	65,495	7.400	74,346	8.400	32,482	3.670	15
KB 0600 -...6	71,691	8.100	80,984	9.150	26,110	2.950	12
KB 0600 -...9	77,886	8.800	87,622	9.900	19,472	2.200	9
KB 0800 -...1	79,656	9.000	91,162	10.300	50,449	5.700	18
KB 0800 -...3	88,064	9.950	99,570	11.250	42,041	4.750	15
KB 0800 -...6	96,473	10.900	107,979	12.200	33,633	3.800	12
KB 0800 -...9	104,881	11.850	116,387	13.150	25,224	2.850	9
KB 1200 -...1	115,059	13.000	132,761	15.000	73,461	8.300	18
KB 1200 -...3	125,680	14.200	143,381	16.200	62,840	7.100	15
KB 1200 -...6	136,301	15.400	154,002	17.400	52,219	5.900	12
KB 1200 -...9	146,922	16.600	163,738	18.500	41,598	4.700	9

Ms = Coppia statica - Static torque

Md = Coppia dinamica - Dinamic torque



KB GRUPPO FRENO - FRIZIONE A COMANDO PNEUMATICO AIR ACTUATED CLUTCH - BRAKE UNIT

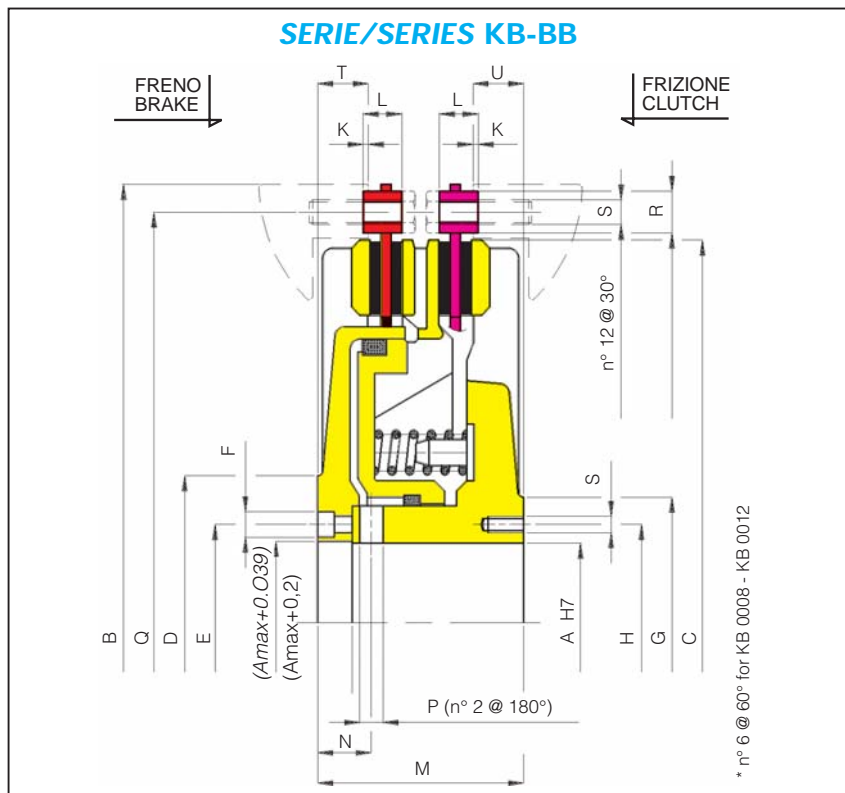

TIPO TYPE	KB 0008		KB 0012		KB 0025		KB 0050		KB 0100		KB 0200		KB 0400		KB 0500		KB 0600		KB 0800		KB 1200			
	inch	mm	inch	mm	inch	mm	inch	mm	inch	mm	inch	mm	inch	mm	inch	mm	inch	mm	inch	mm	inch	mm	inch	mm
A max	0.984	25	1.378	35	1.496	38	1.772	45	2.362	60	3.150	80	3.543	90	3.937	100	4.134	105	4.724	120	5.512	140		
A min	0.630	16	0.827	21	1.024	26	1.142	29	1.693	43	1.890	48	2.126	54	2.441	62	2.520	64	2.835	72	3.150	80		
B	5.91	150	7.40	188	8.66	220	10.83	275	13.86	352	17.20	437	21.06	535	22.44	570	24.41	620	26.77	680	30.51	775		
C	4.80	122	6.14	156	7.40	188	9.29	236	11.97	304	14.96	380	18.31	465	19.57	497	21.38	543	23.35	593	26.57	675		
D	2.64	67	2.76	70	3.35	85	4.33	110	5.35	136	6.50	165	7.17	182	8.27	210	8.43	214	9.37	238	10.47	266		
E	1.69	43	1.89	48	2.01	51	2.48	63	3.15	80	4.13	105	4.53	115	5.12	130	5.31	135	5.98	152	6.89	175		
F	0.43	11	0.35	9	0.35	9	0.43	11	0.55	14	0.67	17	0.75	19	0.75	19	0.75	19	0.87	22	0.98	25		
G	4.80	122	2.76	70	3.35	85	4.09	104	4.53	115	5.91	150	6.30	160	7.48	190	7.80	198	8.27	210	9.06	230		
H	1.69	43	1.89	48	2.01	51	2.48	63	3.15	80	4.13	105	4.53	115	5.12	130	5.31	135	5.98	152	6.89	175		
K	0.04	1	0.08	2	0.08	2	0.12	3	0.12	3	0.12	3	0.16	4	0.16	4	0.16	4	0.16	4	0.20	5		
L	0.47	12	0.47	12	0.47	12	0.55	14	0.83	21	0.98	25	1.10	28	1.26	32	1.30	33	1.50	38	1.26	32		
M	1.89	48	1.97	50	2.28	58	2.60	66	3.27	83	3.94	100	4.92	125	5.51	140	5.71	145	6.10	155	7.28	185		
N	0.37	9,5	0.55	14	0.67	17	0.75	19	0.87	22	1.06	27	1.26	32	1.46	37	1.44	36,5	1.65	42	2.09	53		
P	0.16	4	0.20	5	0.24	6	0.28	7	0.39	10	0.47	12	0.59	15	0.71	18	0.71	18	0.71	18	0.91	23		
Q	5.35	136	6.81	173	8.07	205	10.04	255	12.80	325	16.06	408	19.69	500	21.10	536	22.99	584	25.20	640	28.54	725		
R	0.394	10	0.394	10	0.394	10	0.472	12	0.591	15	0.709	18	0.984	25	0.984	25	0.984	25	1.181	30	1.378	35		
S		M5		M5		M5		M6		M8		M10		M14		M14		M14		M16		M20		
T	0.43	11	0.43	11	0.63	16	0.67	17	0.67	17	0.75	19	0.98	25	1.02	26	1.38	35	1.30	33	1.89	48		
U	0.16	4	0.31	8	0.39	10	0.43	11	0.55	14	0.71	18	1.18	30	1.26	32	0.94	24	1.06	27	1.69	43		
V	-	-	-	-	-	-	-	-	M10	M10	M14	M14	M14	M14	M14	M14	M16	M16	M20	M20				
Z	-	-	-	-	-	-	0.79	20	0.98	25	1,18	30	1,18	30	1,38	35	1,38	35	1,57	40				
W	-	-	-	-	-	-	0.06	1.5	0,08	2	0,08	2	0,08	2	0,08	2	0,10	2.5	0,12	3				
WW	3.74	95	4.29	109	5.35	136	6.81	173	8.19	208	10.43	265	13.39	340	14.57	370	15.75	400	16.73	425	20.00	508		
AA	-	-	-	-	-	-	-	0.59	15	0.89	22,5	1	25,5	1.10	28	1.45	37	1.31	33,5	1.47	37,5			
BB	-	-	-	-	-	-	-	0.47	12	0.93	23,5	1.20	30,5	1.33	34	1	25,5	1.08	27,5	1.28	32,5			
ZZ	3.94	100	4.84	123	5.91	150	7.48	190	9.25	235	11.73	298	14.76	375	15.83	402	17.13	435	18.78	477	21.26	540		
	U.S.	Metric	U.S.	Metric	U.S.	Metric	U.S.	Metric	U.S.	Metric	U.S.	Metric	U.S.	Metric	U.S.	Metric	U.S.	Metric	U.S.	Metric	U.S.	Metric	U.S.	Metric
Massima velocità/RPM Max speed/RPM	3.200	3.200	2.800	2.800	2.500	2.500	2.300	2.300	1.700	1.700	1.400	1.400	1.150	1.150	1.100	1.100	950	950	900	900	800	800		
Peso Kg - Weight LBS	11.0	5	13.2	6	19.8	9	33.1	15	61.7	28	116.9	53	220.5	100	297.7	135	348.4	158	445.4	202	639.5	290		
Valore Cilindro (nuovo) lt Cylinder capacity (new) IN ³	1.22	0,02	3.05	0,05	4.27	0,07	9.15	0,15	14.65	0,24	24.41	0,40	36.61	0,60	42.72	0,70	54.92	0,90	79.33	1,30	109.84	1,80		
Valore Cilindro (usurato) lt Cylinder capacity (worn) IN ³	2.44	0,04	5.49	0,09	8.54	0,14	14.04	0,23	25.02	0,41	42.72	0,70	67.13	1,10	79.33	1,30	91.54	1,50	128.15	2,10	170.87	2,80		
Inerzia J Corpo Kgm ² Inertia WR ² Body LB-FT	0.17	0,007	0.24	0,010	0.45	0,019	1.30	0,055	4.15	0,175	12.46	0,525	35.59	1,500	49.82	2,100	77.11	3,250	118.63	5,000	207.60	8,750		
Inerzia J Anelli Kgm ² Inertia WR ² Plates LB-FT	0.07	0,003	0.09	0,004	0.19	0,008	0.59	0,025	1.49	0,063	4.75	0,200	13.64	0,575	19.57	0,825	27.88	1,175	43.89	1,850	88.97	3,750		
Momento freno Nm Brake torque LB-IN	310	35	708	80	1.416	160	2.921	330	5.753	650	12.390	1.400	24.780	2.800	300.900	34.000	38.940	4.400	50.445	5.700	73.455	8.300		
Momento frizione (5,5 bar) Nm Clutch torque (@ 80 Psi) LB-IN	575	65	1.151	130	2.124	240	5.045	570	9.293	1.050	18.585	2.100	39.825	4.500	47.790	5.400	59.295	6.700	79.650	9.000	115.050	13.000		

Pressione di esercizio 5,5 Bar - Operating pressure 80 Psi - Pressione massima ammissibile 6 Bar - Max. Allowable pressure 87 Psi



KB

SERIE - SERIES KB

KB

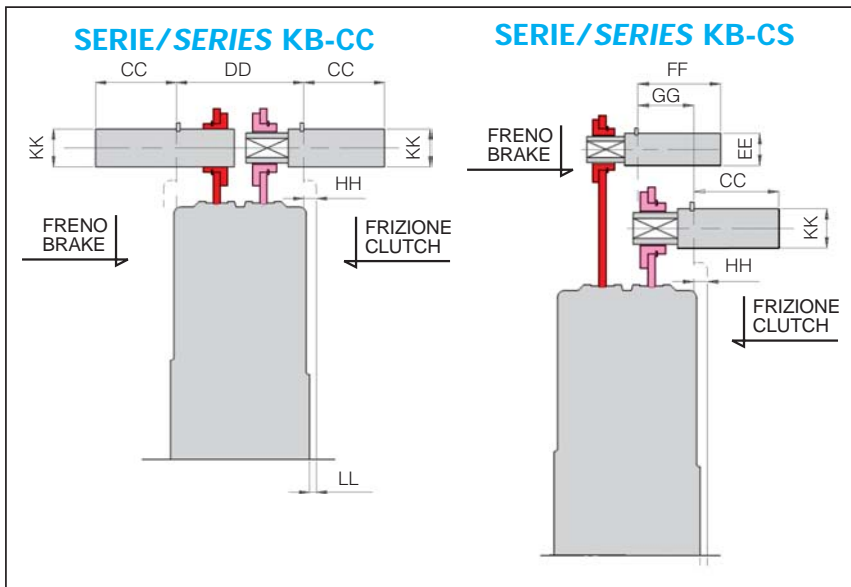
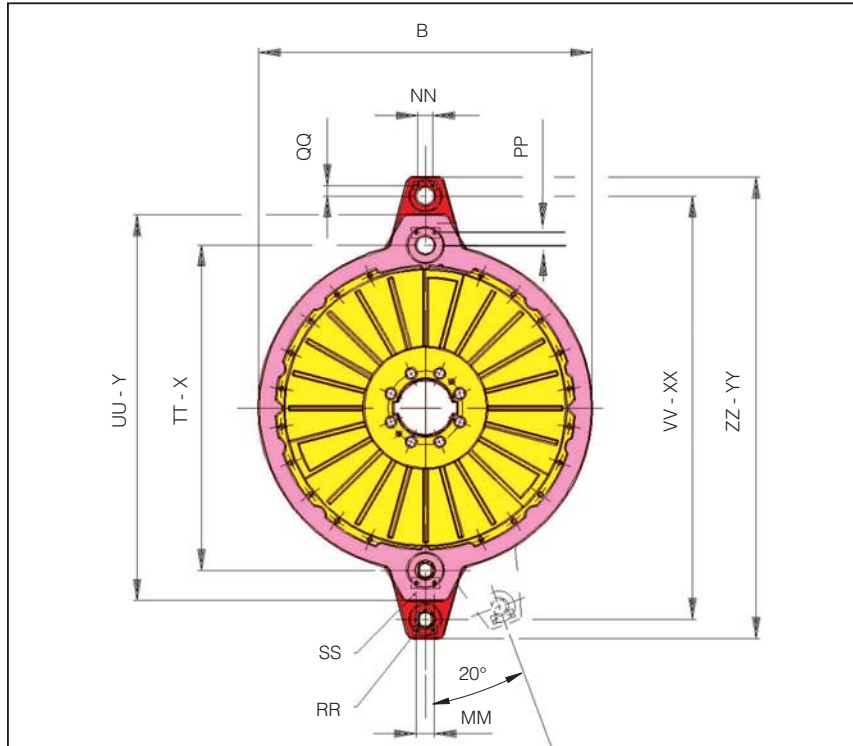
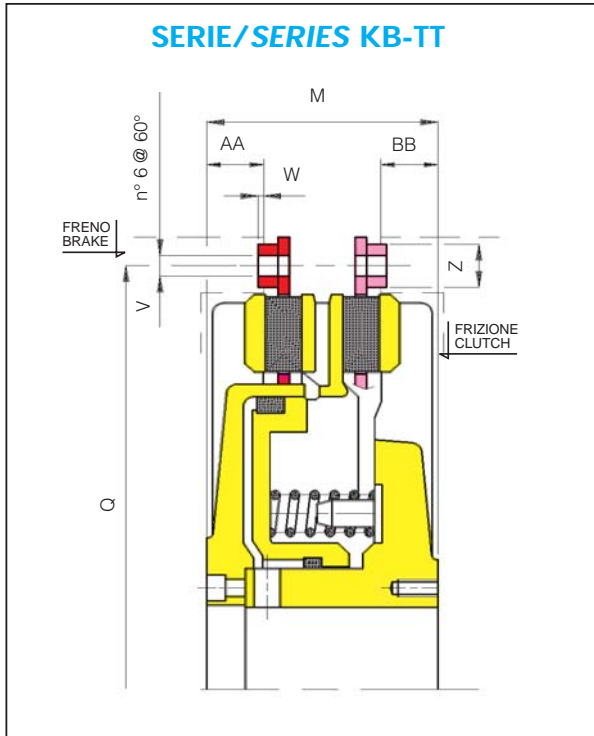

TIPO TYPE	KB 0025		KB 0050		KB0100		KB 0200		KB 0400		KB 0500		KB 0600		KB 0800		KB 1200	
	inch	mm	inch	mm	inch	mm	inch	mm	inch	mm	inch	mm	inch	mm	inch	mm	inch	mm
CC	1.10	28	1.77	45	1.77	45	2.36	60	3.15	80	3.15	80	3.15	80	3.54	90	4.33	110
DD	2.40	61	2.76	70	2.76	70	4.02	102	4.69	119	4.92	125	4.96	126	5.79	147	6.22	158
EE	0.630	16	0.630	16	0.630	16	0.866	22	1.181	30	1.181	30	1.181	30	1.575	40	1.772	45
FF	1.10	28	1.10	28	1.10	28	1.77	45	2.36	60	2.36	60	2.36	60	31.61	80	3.54	90
GG	0.87	22	1.10	28	1.18	30	1.89	48	1.89	48	2.09	53	2.64	67	3.03	77	3.70	94
HH	0.00	0	0.00	0	0.59	15	0.39	10	0.63	16	0.83	21	0.55	14	0.43	11	0.16	4
KK	0.630	16	0.866	22	0.866	22	1.181	30	1.575	40	1.575	40	1.575	40	1.772	45	2.165	55
LL	0.197	5	0.236	6	0.394	10	0.394	10	0.394	10	0.394	10	0.394	10	0.394	10	0.787	20
MM	0.79	20	0.98	25	0.98	25	0.98	25	1.38	35	1.38	35	1.38	35	1.38	35	1.77	45
NN	0.79	20	0.79	20	0.79	20	0.98	25	0.98	25	0.98	25	0.98	25	1.38	35	1.38	35
PP	0.43	11	0.63	16	0.63	16	0.79	20	1.06	27	1.06	27	1.06	27	1.16	29.5	1.52	38.5
QQ	0.43	11	0.43	11	0.43	11	0.63	16	0.79	20	0.79	20	0.79	20	1.06	27	1.16	29.5
RR	0.177	4.5	0.177	4.5	0.177	4.5	0.217	5.5	0.217	5.5	0.217	5.5	0.217	5.5	0.256	6.5	0.256	6.5
SS	0.177	4.5	0.217	5.5	0.217	5.5	0.217	5.5	0.256	6.5	0.256	6.5	0.256	6.5	0.256	6.5	0.335	8.5
TT	9.13	232	11.65	296	14.33	364	17.52	445	21.65	550	22.64	575	25.20	640	26.93	684	30.51	775
UU	11.024	280	13.858	352	16.457	418	20.669	525	25.197	640	26.378	670	29.134	740	31.299	795	35.551	903
VV	13.386	340	17.953	456	22.047	560	25.591	650	31.496	800	32.913	836	36.614	930	39.370	1.000	45.669	1.160
ZZ	15.20	386	19.76	502	23.82	605	27.76	705	34.65	880	36.02	915	39.76	1.010	43.11	1.095	50.08	1.272
X	9.84	250	12.40	315	15.35	390	19.49	495	24.02	610	25.39	645	27.36	695	30.31	770	34.65	880
Y	11.65	296	14.61	371	17.52	445	22.44	570	27.56	700	29.13	740	31.10	790	34.65	880	39.69	1.008
XX	12.80	325	16.14	410	19.29	490	25.00	635	31.10	790	32.68	830	34.84	885	38.98	990	44.69	1.135
YY	14.61	371	17.95	456	21.06	535	27.36	695	34.25	870	35.83	910	37.99	965	42.72	1.085	49.09	1.247



FLANGIA ADDUZIONE ARIA (solo per montaggio a sbalzo - opzionale) SUFFISSO F AIR INLET FLANGE - optional (for end assembly only) SUFFIX F

SUFFIX F (Standard version)
SUFFISSO F (esecuzione standard)

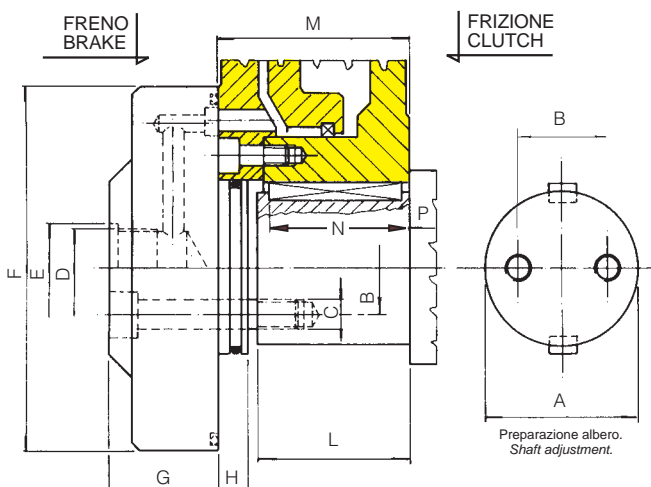

SUFFIX F₁ (Single bolt version) For types: 0025-0050
Use only if necessary.

SUFFISSO F₁ (esecuzione monoforo) Per i tipi: 0025-0050
Impiegare solo in caso di necessità.

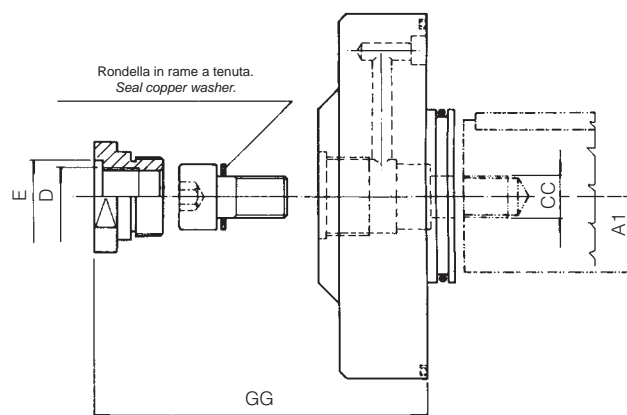

TIPO TYPE	KB 0008		KB 0012		KB 0025		KB 0050		KB 0100		KB 0200		KB 0400		KB 0500		KB 0600		KB 0800		KB 1200			
	inch	mm	inch	mm	inch	mm	inch	mm	inch	mm	inch	mm	inch	mm	inch	mm	inch	mm	inch	mm	inch	mm	inch	mm
A-A₁ max	0.984	25	1.378	35	1.496	38	1.772	45	2.362	60	3.150	80	3.543	90	3.937	100	4.134	105	4.724	120	5.512	140		
A min	-	-	-	-	1.260	32	1.378	35	1.772	45	2.165	55	2.559	65	2.559	65	2.992	76	3.110	79	3.346	85		
A₁ min	0.787	20	0.98	25	1.10	28	1.26	32	-	-	-	-	-	-	-	-	-	-	-	-	-	-	-	-
B	-	-	-	-	0.98	25	1.02	26	1.34	34	1.65	42	1.97	50	1.97	50	2.40	61	2.40	61	2.56	65		
C	-	-	-	-	M5		M6		M8		M10		M12		M12		M12		M14		M16			
CC	0.26	6.5	0.43	11	0.43	11	0.43	11	-	-	-	-	-	-	-	-	-	-	-	-	-	-	-	-
D	1/4"	1/4"G	1/4"	1/4"G	1/4"	1/4"G	1/4"	1/4"G	3/8"	3/8"G	1/2"	1/2"G	3/4"	3/4"G	3/4"	3/4"G	1"	1"G	1"	1"G	1"	1"G	1"	1"G
E	0.630	16	0.630	16	0.630	16	0.630	16	0.787	20	0.984	25	1.181	30	1.181	30	1.378	35	1.378	35	1.378	35		
F	2.83	72	2.83	72	3.50	89	4.33	110	5.35	136	6.50	165	7.17	182	8.27	210	8.46	215	9.37	238	10.47	266		
G	-	-	-	-	1.18	30	1.18	30	1.38	35	1.65	42	1.69	43	1.89	48	2.05	52	2.05	52	2.13	54		
GG	1.81	46	1.81	46	1.81	46	1.81	46	-	-	-	-	-	-	-	-	-	-	-	-	-	-	-	-
H	0.315	8	0.315	8	0.315	8	0.315	8	0.315	8	0.315	8	0.315	8	0.315	8	0.315	8	0.315	8	0.315	8	0.315	8
L	1.57	40	1.57	40	1.89	48	2.20	56	2.87	73	3.54	90	4.53	115	5.12	130	5.31	135	5.51	140	6.89	175		
M	1.89	48	1.97	50	2.28	58	2.60	66	3.27	83	3.94	100	4.92	125	5.51	140	5.71	145	6.10	155	7.28	185		
N	1.50	38	1.50	38	1.65	42	2.05	52	2.56	65	3.27	83	4.06	103	4.45	113	4.45	113	5.04	128	5.63	144		

CONVERSION FACTORS

TO CONVERT	INTO...	MULTIPLY BY...
CENTIMETER (CM)	INCH	0.39
FOOT (FT)	INCH	12
FOOT	METER	0.30
METER (M)	FEET	3.281
MILLIMETER	INCH	0.039
FT2	M2	0.09
IN2	CM2	6.45
GALLON (US)	IN3	231
GALLON (IMP)	IN3	277.42
GALLON (IMP)	GALLON (US)	1.2
IN3	CM3	16.39
LITER	GALLONS (US)	0.26
LITER	GALLONS (IMP)	0.22
LITER	IN3	61.03
KILOGRAM (KG)	LB	2.20
POUND (LBS)	KG	0.45
TON (METRIC)	TON (SHORT)	1.103
KP	LBF	2.2
NEWTON (N)	LB	0.22
ATMOSPHERE	LB/IN2	14.7
ATMOSPHERE	KP/CM2	1.03
BAR	ATMOSPHERES	0.987
BAR	LB/IN2	14.5
KP/CM2	LB/IN2	14.22
LB/IN2	BAR	0.069
LB/IN2	KG/CM2	0.07

TO CONVERT	INTO...	MULTIPLY BY...
KP-M	LB-IN	86.8
LB-FT	NM	1.356
LB-IN	NM	0.113
NM	LB-IN	8.85
NM	LB-FT	0.74
BTU/MIN	HP	0.023
BTU/MIN	KW	0.017
HORSEPOWER (HP)	BTU/MIN	42.44
HP	FT-LB/MIN	33000
HP	FT-LB/SEC	550
HP	KW	0.74
HP	WATT	745.7
KILOWATT (KW)	HP	1.341
KW	BTU/MIN	56.92
WATT	HP	0.0013
BTU	FT-LB	778.3
BTU	JOULES	1055
FT-LB	BTU	0.0012
JOULE	BTU	0.0009
J	WR2	23.73
KG-M2 (J)	LB-FT2 (WR2)	23.73
KP-M2 (GD2)	KG-M2 (J)	4
KP-M2 (GD2)	LBF-FT2 (WK2)	5.93
LBF-FT2 (WK2)	LB-FT2 (WR2)	4
DEGREE	RADIAN	0.017
RADIAN	DEGREE	57.29



ALTRI PRODOTTI OTHER PRODUCTS

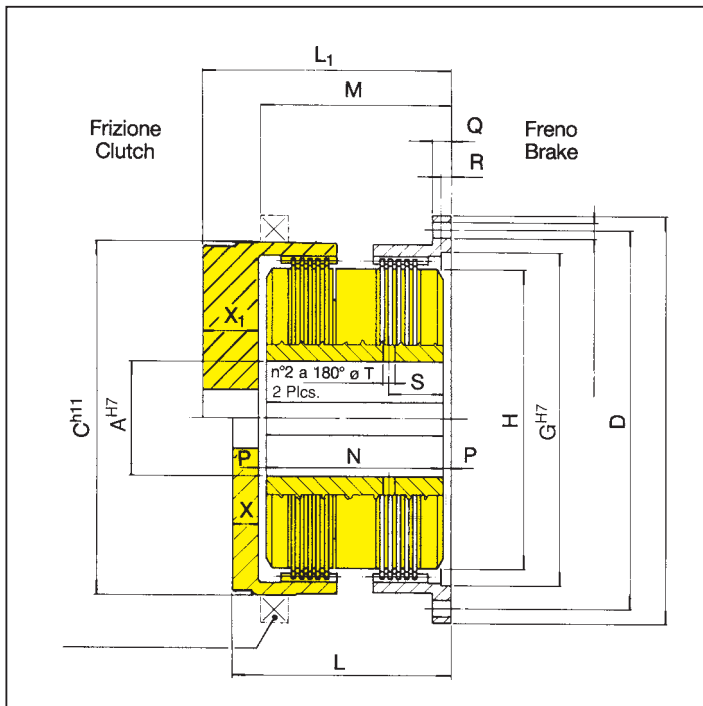

SERIE/SERIES WW

Gruppi Frizione-Freno in bagno d'olio a comando idraulico
Wet Clutch/Brake units, hydraulically actuated

Coppie da 2.550 Nm
a 455.809 Nm
Torque values: from 2.550 Nm (22,540 Lb-in)
to 455.809 Nm (403,3910 Lb-in)

SERIE/SERIES SK

Frizioni Mono/Multi Disco a comando pneumatico
Single or Multi disks air actuated Clutch units

Coppie da 270 Nm
a 284.500 Nm
Torque values: from 270 Nm (2,392 Lb-in)
to 284.500 Nm (2,517,825 Lb-in)

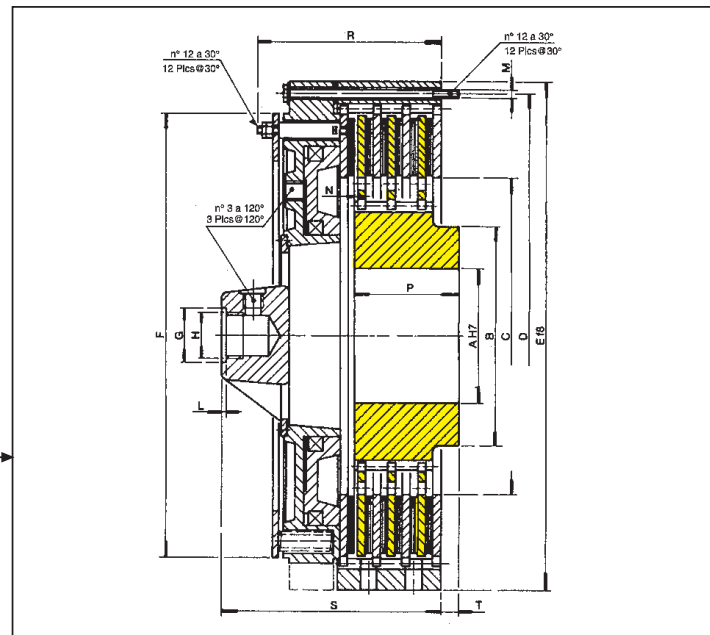

SERIE/SERIES SB

Freni a pressione di molle (apertura pneumatica)
Spring loaded Brake (air release)

Coppie da 90 Nm
a 310.750m
Torque values: from 90 Nm (797 Lb-in)
to 310.750 Nm (2,750,140 Lb-in)

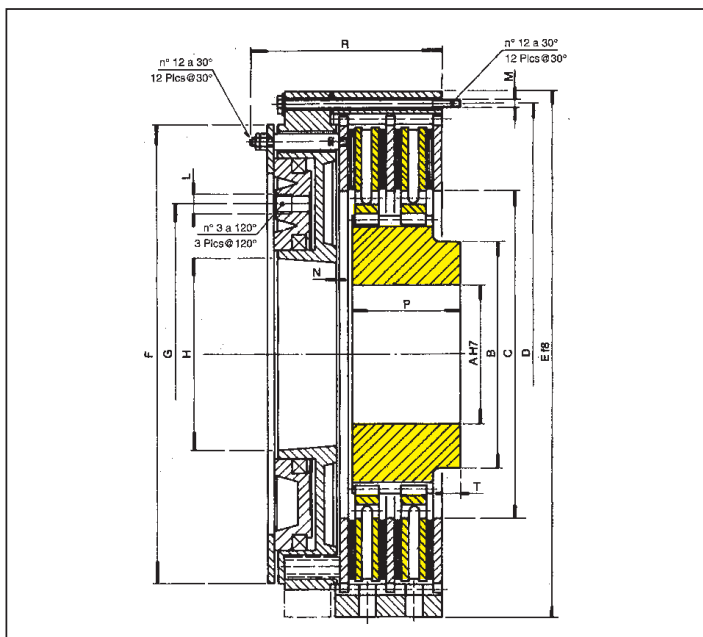

Ci riserviamo il diritto di effettuare modifiche, dettate dal aggiornamento tecnico, senza preavviso.
Due to technical updatings, we reserve the right to make changes without previous notice.





ESEMPI DI MONTAGGIO, flange con O-R a cura dell'utilizzatore
LAY OUT EXAMPLES, flanges and O-R supplied by customer

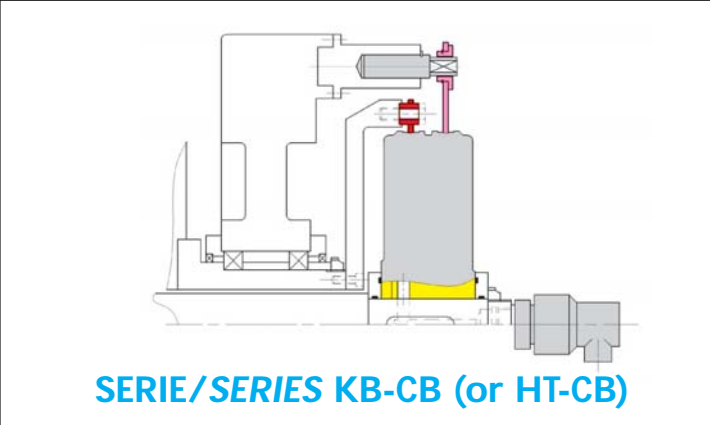

SERIE/SERIES KB-CB (or HT-CB)

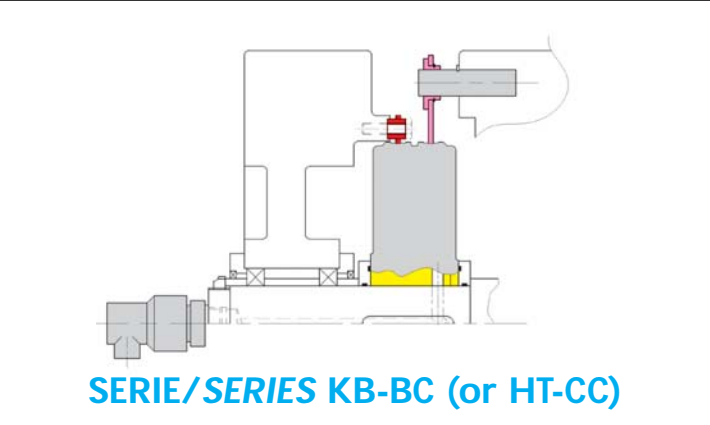

SERIE/SERIES KB-BC (or HT-CC)

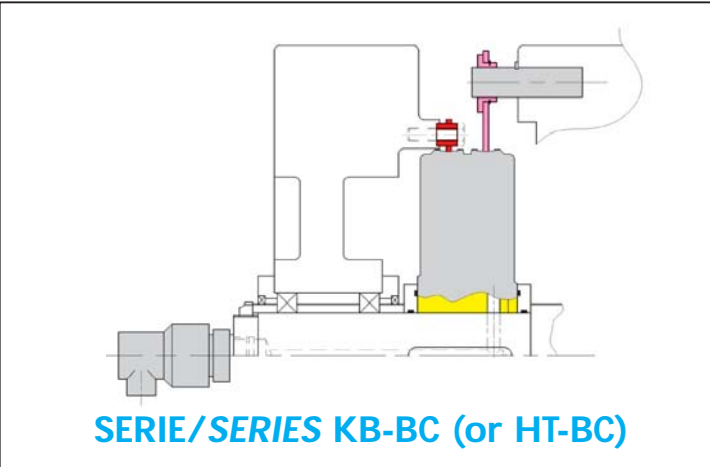

SERIE/SERIES KB-BC (or HT-BC)

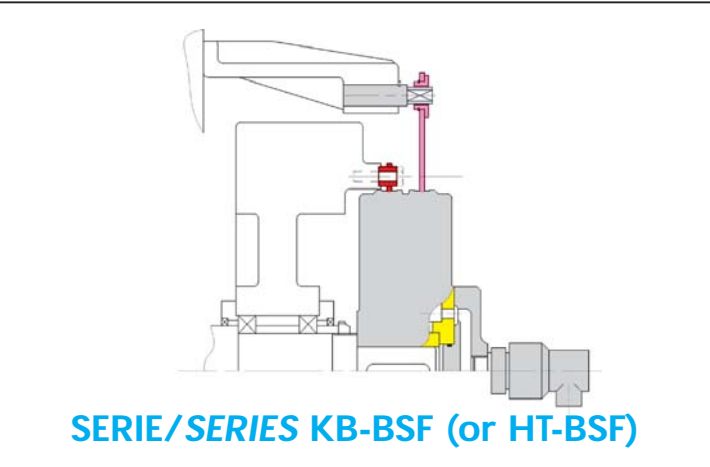

SERIE/SERIES KB-BSF (or HT-BSF)

www.aziendaimmagine.com - 12/2001

AMBI CORP
Chicago (Usa)

OMPI srl
Milano (Italy)

ed. 01/2002



22530 S.CENTER RD Frankfort, IL 60423 - U.S.A.
Phone (815) 469-9875 - Fax (815) 469-9891



20048 CARATE BRIANZA (MI) ITALY - Via Piemonte, 14
Tel. 0362/912220-905204-931975 - Fax 0362/993204